

PACK CODE JAR2515-6oz  
 PACK TYPE J A R S  
 CATEGORY Skincare

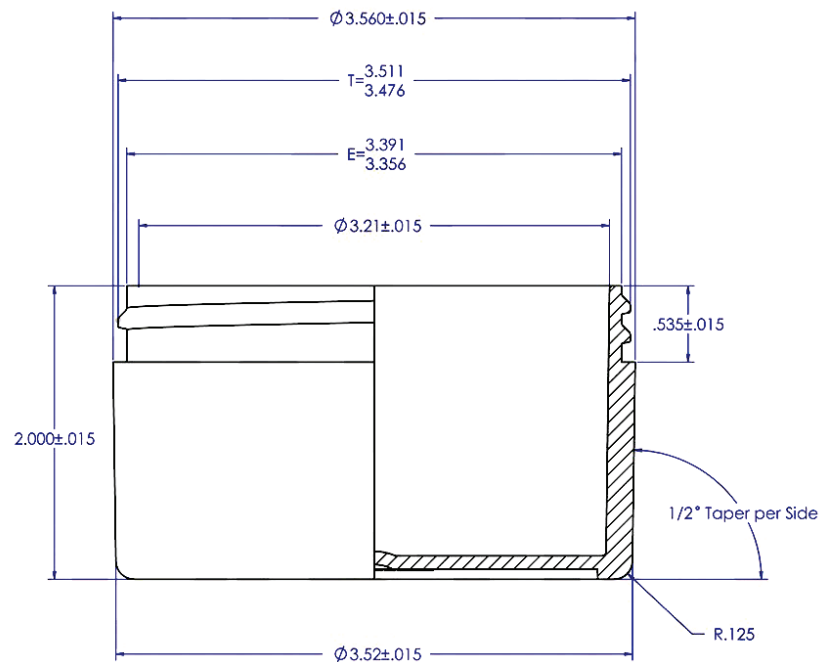

## PRODUCT DATA SHEET

**DESCRIPTION** Single thick wall jar all PP 6oz (also available in 1, 2, 4, 8, 12 & 16oz)

**BENEFITS**

- Maximum compatibility with your formula
- Optimum robustness thanks to the thick wall
- Price efficient
- Easy top filling (fill & screw on cap)
- Wide range of decoration
- Evacuation rate 100%



**APPLICATIONS** Creams, lotions, moisturizer, gel

### TECHNICAL SPECIFICATIONS

#### GENERAL INFORMATION

#### PRODUCTION & PACKING

##### DIMENSIONS

Total Height	2,000±0.15
Diameter	3.52±0.15

##### PRODUCTION

Lead time	4 - 6 weeks
MOQ	10k
Plant location	USA

#### MATERIALS

Jar	PP
Cap	PP

#### PACKING SPECS

	Carton Size	N.W	Qty/Ctn
Jar	20" x 14" x 14.5"	21.2 lbs.	140
Smooth cap	20" x 14" x 14.5"	14.3 lbs.	370
Dome cap	20" x 14" x 14.5"	14.3 lbs.	350

#### CAPACITY

Declared	6oz
OFC	240ml ± 3%

#### DECO OPTIONS

**Jar**  
 Injection color, silk screen, hot stamping  
**Cap**  
 Injection color, silk screen, hot stamping